



WING CHEONG ELECTRICAL COMPANY
WING CHEONG ELECTROACOUSTIC INDUSTRIAL LIMITED

CUSTOMER		
SPECIFICATIONS	WCB0622UM02	
DIMENSIONAL	Ø6.0×2.2mm	
SENSITIVITY	-47±3dB (0dB=1V/Pa at 1 KHz) 2.0V 2.2KΩ	
CUSTOMER MODEL		
VENDOR		CUSTOMER
MADE BY	CHECKED BY	APPROVED BY
Revision level	Description of changes	Changed date



TYPE: WCB-0622UM02

1. BACK ELECTRICAL CHARACTERISTICS

1.1 TEMP=20±2°C

Room Humidity=65±5%

PARAMETER	SYMBOL	CONDITION	LIMITS			UNIT
			Min	Center	Max	
Sensitivity	S	f=1KHZ,S.P.L=1Pa 0dB=1V/Pa	-50	-47	-44	dB
Output impedance	Zout	f=1KHZ		2.2		KΩ
Current Consumption	IDss	VS=2.0V RL=2.2KΩ			500	A
Directivity	Unidirectional					
Signal to Noise Ratio	S/N	S:(f=1KHz,S.P.L=1Pa) N:(A-Weighted curve)		52		dB
Decreasing Voltage	ΔS-VS	Vs=2.0V to 1.5V			-3	dB
Sensitivity Δ0°~180°		f=1KHz, S.P.L=1Pa	8			dB
Operating voltage			1.0		5.0	V
Maximum input S.P.L		f=1KHZ , THD < 1%		100		dB



1.2 TYPICAL FREQUENCY RESPONSE CURVE

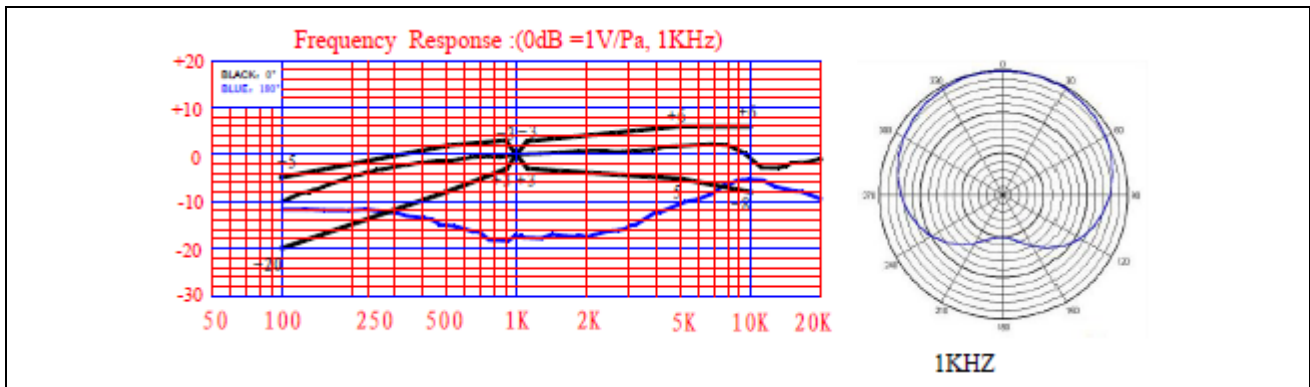

2. MEASUREMENT CIRCUIT

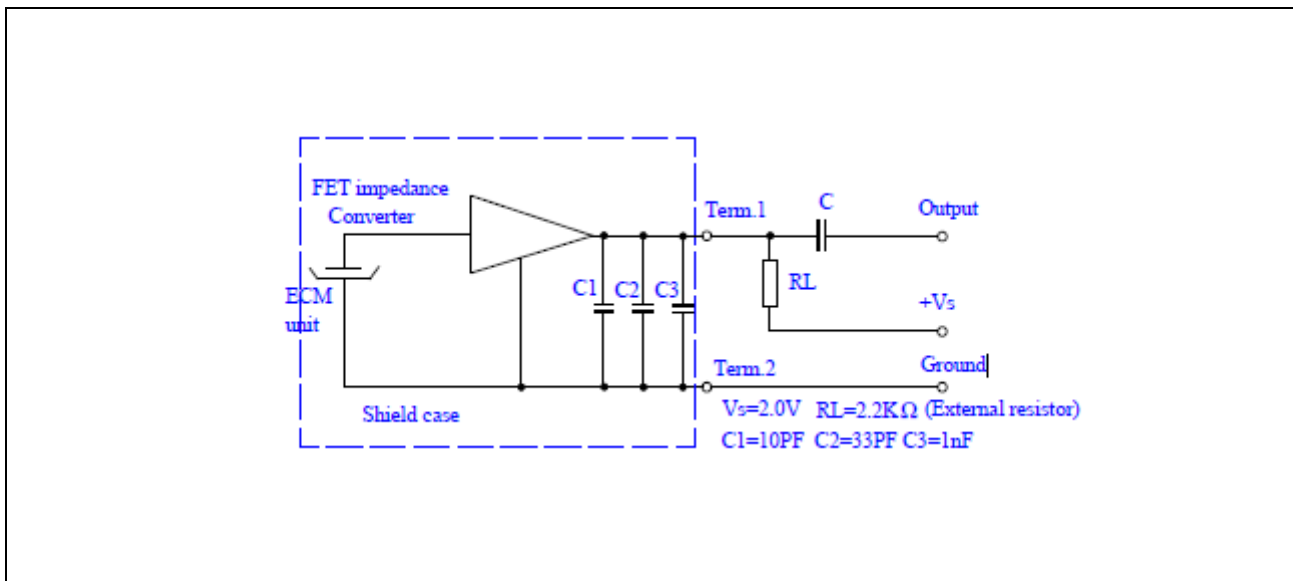



3. APPEARANCE & DIMENSIONS

Unit: mm

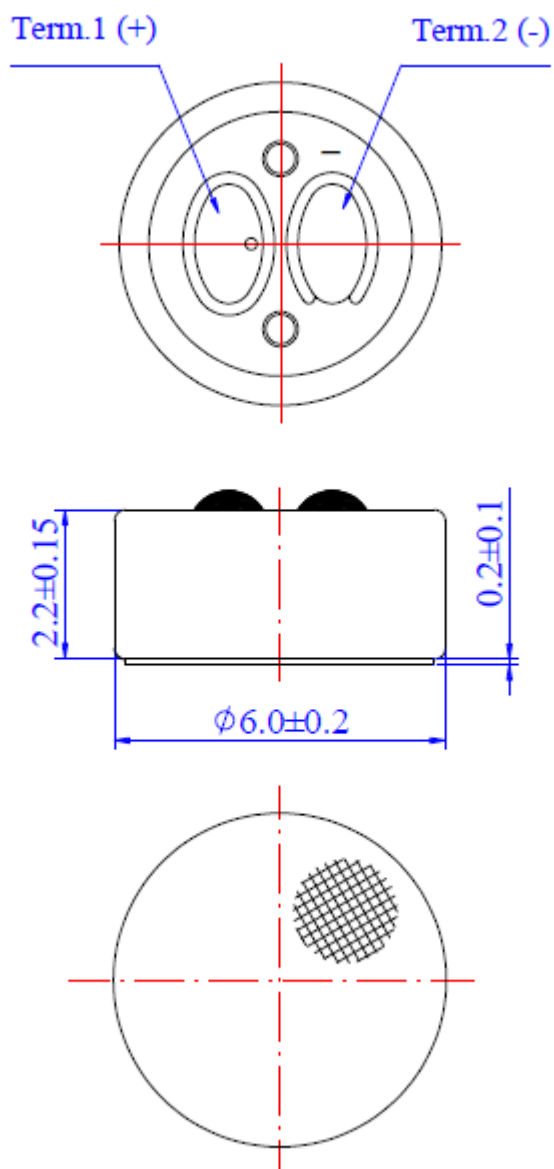

DIMENSIONS : $\phi 6.0 \times 2.2$ mm

ECM : WCB-0622UM02



4. MECHANICAL CHARACTERISTICS

Soldering Heat Shock	To be no interference in operation after soldering Heat shock, temperature $320^{\circ}\text{C}\pm 20^{\circ}\text{C}$ for 2 ± 1 seconds
Terminal Mechanical Strength	To be no interference in operation after pulled the terminal with 0.5 kg strength for 3 seconds.

5. RELIABILITY TEST

All tests are to be carried out on the same test batch in the order listed.

The sensitivity to be within $\pm 3\text{dB}$ of initial sensitivity after 3 hours of conditioning at 20°C .

Temperature Test	After exposure at 60°C for 96hours, the sensitivity to be within $\pm 3\text{dB}$ from the initial value.
	After exposure at -25°C for 96 hours the sensitivity to be within $\pm 3\text{dB}$ from the initial value.
Humidity Test	After exposure at 40°C and 90~95% relative humidity for 96 hours, the sensitivity to be within $\pm 3\text{dB}$ from the initial sensitivity.
Temperature Cycle Test	After exposure at -25°C for 30 minutes, at 20°C for 10 minutes, at $+60^{\circ}\text{C}$ for 30 minutes, at 20°C for 10 minutes, 5 cycles, the sensitivity to be within $\pm 3\text{dB}$ from the initial value.



Vibration Test	To ensure no effect on the use of vibrations, 50Hz at full amplitude of 1.52mm, for 2 hours at 1 anises test are carried out.
Drop Test	To ensure no effect on use after being dropped, the test microphone dropped on a concrete floor from a height of 1-meter.

6. CONCEPT OF UNIT

The difference between the concept of unit “Pascal” and the one of unit “μbar” can be explained as follows. In calibrating the sensitivity of ECMs,

The sensitivity is manifested differently according to as the unit is “Pascal” or “μbar”.

That is, the sensitivity will be increased by 20 dB in the usage of unit “Pascal”.

Example: $-60\text{dB} (0\text{dB}=1\text{V}/\mu\text{bar}) = -40\text{dB} (0\text{dB}=1\text{V}/\text{Pa})$



7. SENSITIVITY STANDARD TESTING

7.1 SENSITIVITY

7.2 REQUEST:

The tolerance of sensitivity is not over $\pm 3\text{dB}$ to the standard microphone.

7.3 TESTING WAY:

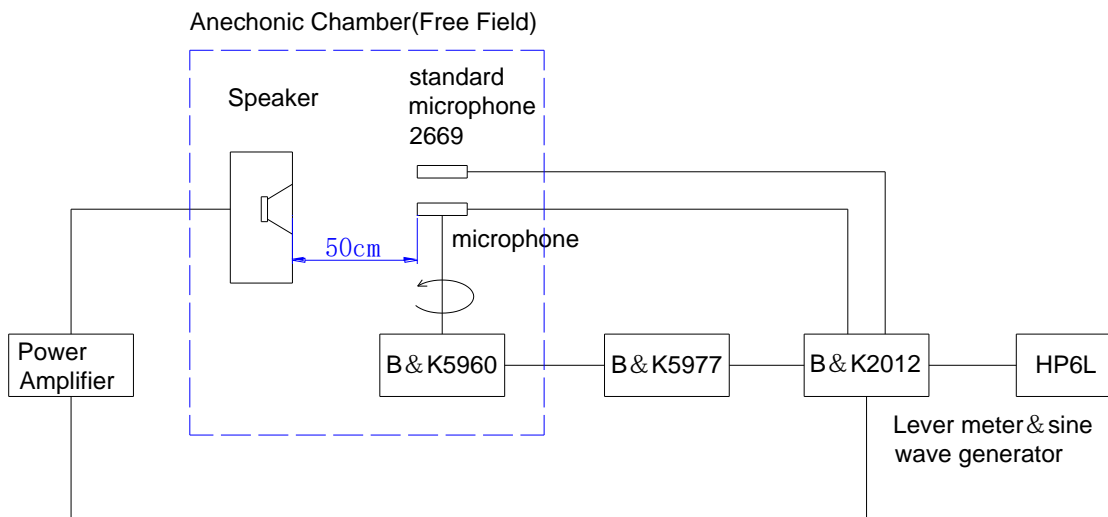

7.3.1 Testing microphone with the standard operating condition.

7.3.2 Put the microphone and standard microphone to face the sound output place (speaker), the distance from sound output to microphone & standard microphone is 50cm. And keep the center distance 5cm between each other to ensure the sound pressure change should be keep in $\pm 1\text{dB}$.

7.3.3 Keep the output sound pressure in $\pm 1\text{dB}$ from the speaker. (Tested by standard microphone)



7.3.4 The sensitivity of microphone is getting its output voltage when sound output keeps in 1000Hz & 1Pa.

7.4 Testing Condition

In Normal Weather

Environment Temperature : 5 ~ 35°C

Relative Humidity : 45 ~ 85%

Air Pressure : 86 ~ 106Kpa

In Arbitrate Weather

Environment Temperature : 20 +/- 2°C

Relative Humidity : 60 ~ 70%

Air Pressure : 86 ~ 106Kpa



8. REGARDING THE SOLDERING OPERATION

MIC is a kind of very sensitive components for temperature and static impacting because there is a FET and a vibrant diaphragm , and FET is destroyed by strong heat and static ; Diaphragm is destroyed by strong heat. If the operation is unsuitable or protect bad during the soldering process , it will affect MIC function and even destroy , So pay attention the following request when soldering :

8.1. Solder temperature and time

8.1.1. Suggest Iron of constant temperature;

8.1.2. Suggest lead-free soldering temperature range $320^{\circ}\text{C}\pm 20^{\circ}\text{C}$ (external soldering temperature of Iron needle) ;

8.1.3. The tual temperature of the user is according to PCB layers and soldering way to adjust soldering temperature.

8.1.4. Ldering skill: soldering time of single point is within 2 seconds ; Don't continue soldering same mic (please repair soldering once badly after cooling it)

8.1.5. Belongs to normal phenomenon that the sensitivity of the microphone change 0.5dB to 1dB within stipulating soldering temperature and time range.

8.1.6. If soldering temperate of the mic increase and time prolong, Sensitivity will have a big change , and even destroy inner structure , performance.

8.2. Soldering Quality

The soldering point can't leave sand hole or empty hole after soldering. (sand hole or empty hole will affect sensitivity and performance) continuous soldering phenomena.

8.3. Static protecting

Electric iron、test machine work stand、 soldering tool must effectively connect earth. The operator must wear ring of resisting static.

8.4. Heat scattered defending

8.4.1. Using heat scattered tool , Choose Al or Cooper , Please refer the following drawing

8.4.2. The heat scattered tool of user, whose shape need according to actual the position of soldering product and space to design or increase blow air tool for scattering heat.

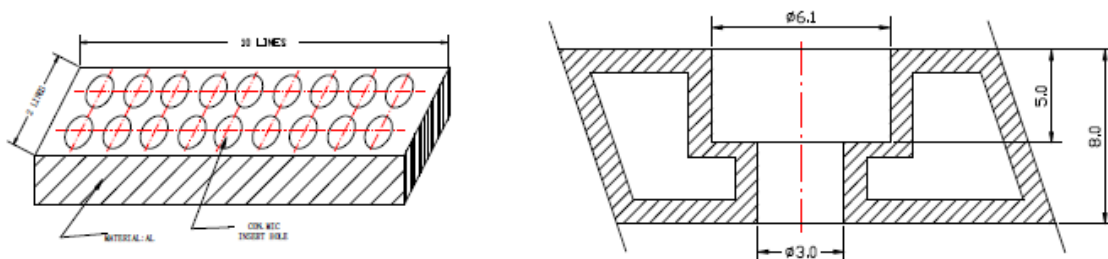

A good package will help Mic. on using normal transportation. Please pay more

attention to prevent humid, shake, sunlight and heavy press.



9. TEMPERATURE CONDITONS

The full packed Mic. Should be store at warehouse in $-20 \sim +70^{\circ}\text{C}$, and the relative humidity not bigger than 90%. The warehouse must keep constant temperature, without acid or any other poisonous gas, and not caused any influence from strong magnetic field.

Operating Temperature Range : $-20^{\circ}\text{C} \sim +70^{\circ}\text{C}$